

VETORBOMBAS

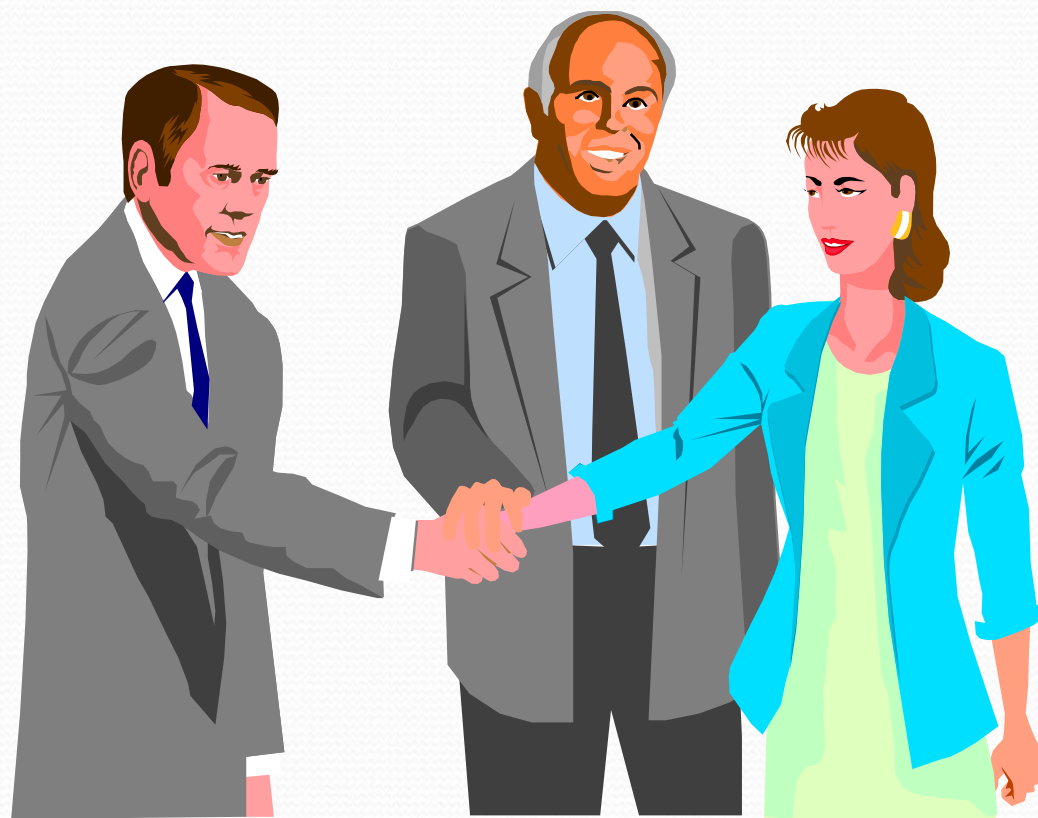

APRESENTAÇÃO

Desde 2004 no mercado de bombas, vedações e serviços a **VETOR BOMBAS** atua em conjunto com os departamentos de suprimentos, manutenção e engenharia visando reduzir os custos de manutenção, aumentando a confiabilidade dos equipamentos e reduzindo o investimento em estoque.

A atuação tem foco nas atividades ligadas ao bombeamento de fluídos e seus desdobramentos. Seja fornecendo, adequando bombas e selagens ou realizando recuperação de peças e tubulações contamos com relações sólidas com as empresas que distribuimos ou representamos visando atender da melhor forma as expectativas do mercado industrial.



Soluções em Bombeamento



F1. Bombas de médio porte

F2. Fundição de ferro fundido e aço INOX/WCB

F3. Centro de desenvolvimento

F4. Bombas de grande porte

F5. Bombas de pequeno porte

F6. Contratos e serviços de manutenção

F7. Fundição de precisão

F8. Acoplamento e expedição

F10. Bombas para óleo e gás

VETORBOMBAS →

03 Fundições próprias na área industrial:

- ❖ FUNDIÇÃO – Ferro Fundido (GG-20 e GGG-40), Com capacidade de fundir mais de 500ton/mês com Peso Bruto de até 9 toneladas.



- ❖ FUNDIÇÃO IMBILINOX – Ligas de aços especiais tais como: Inox, Ferro Branco (Ni-Hard), CD4MCu e hastelloys. Capacidade de 70 ton/mês, com possibilidade de fundir 210 ton/mês.

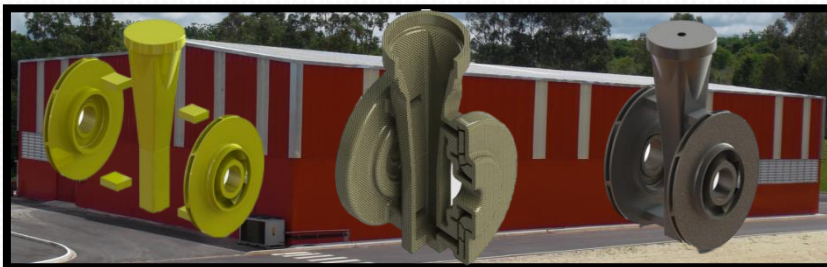

- ❖ MICROFUSÃO: Alta precisão dimensional; Melhor acabamento superficial.

Teste de Performance

Vazão : 0-1800 m³/h

Pressão na sucção: (-) 9 a 30 mca

Pressão no recalque : 1.000 mca

Potência máxima : 1.000 cv (4160 V)



Vazão : 0-10.000 m³/h

Pressão na sucção : (-) 2 mca

Pressão no recalque -: 200 mca

Potência máxima - 1.000 cv (4160 V)



Ferramentas e Softwares

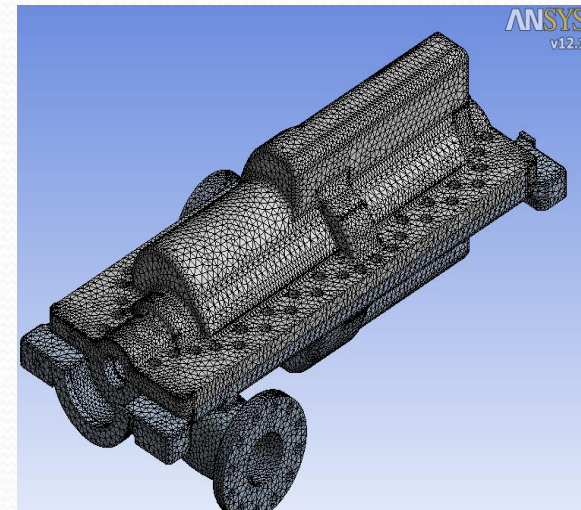
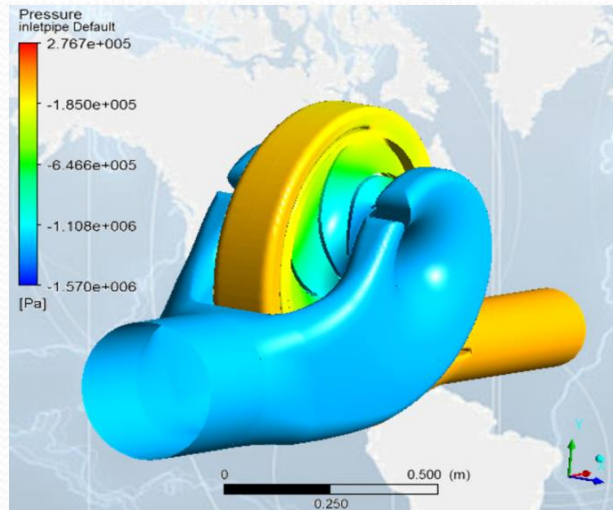
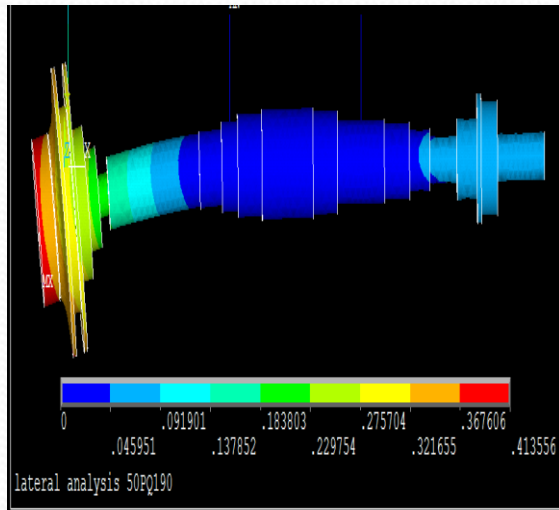
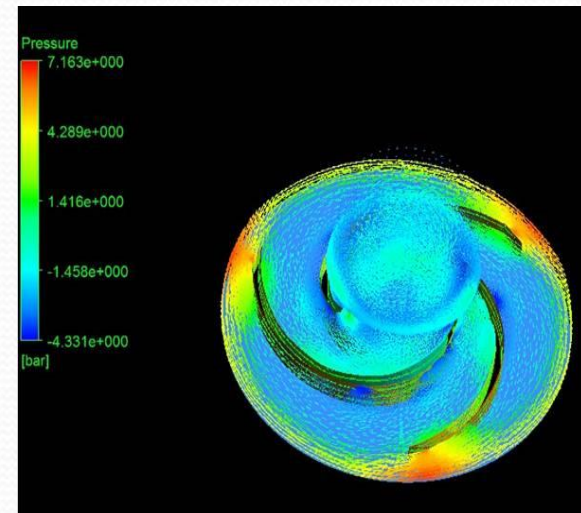
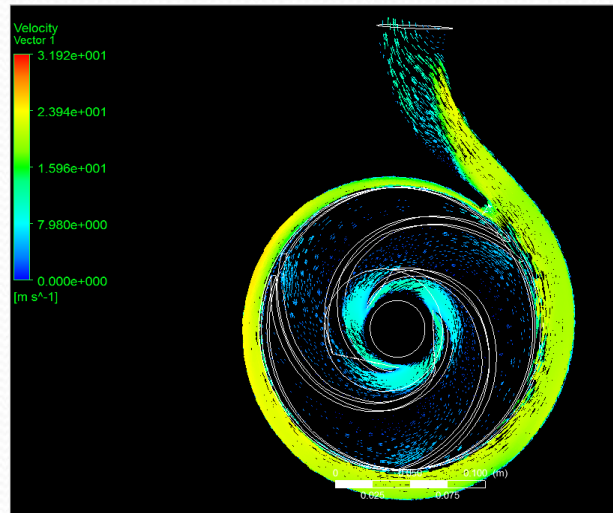



Soluções em Bombeamento

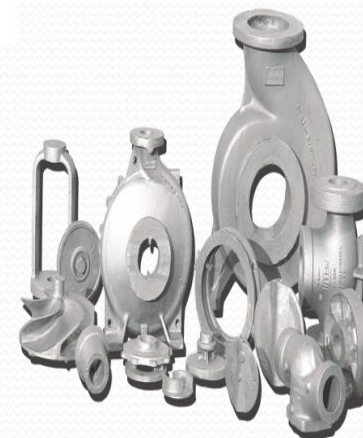
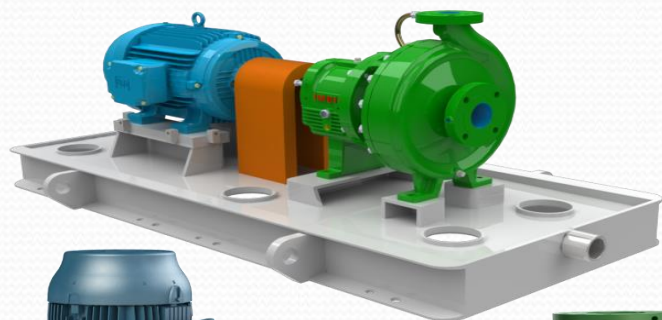

VETORBOMBAS



CHESTERTON[®]

Global Solutions, Local Service.

- 133 Anos
- 100 Países (980 Distribuidores)
- ISO 9001 /ISO 14001
- Matriz – Boston - USA
- Fábrica Brasil: Santo André – SP



CHESTERTON®

Global Solutions, Local Service.

10K Super Monoseal®
5K Super Wiper®
7K Supercup®
8K Super Parachute®

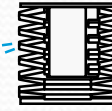

Live-Loading

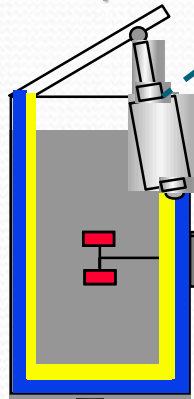

Gear Box

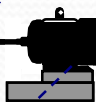

Motor

Ancillary Devices



Live-Loading

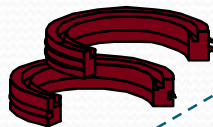

280



442



180

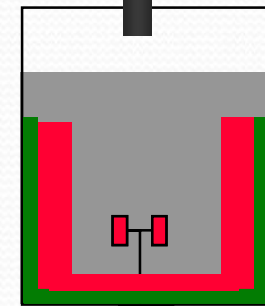

Gear Box



Motor

VETORBOMBAS



CHESTERTON®

Global Solutions, Local Service.

Soluções Gaxetas e Juntas

Mechanical Packing & Gasketing

Leadership through innovation

Packing for...

- Rotating Equipment
- Valve Sealing

Gasketing

Live-Loading

Online Calculators

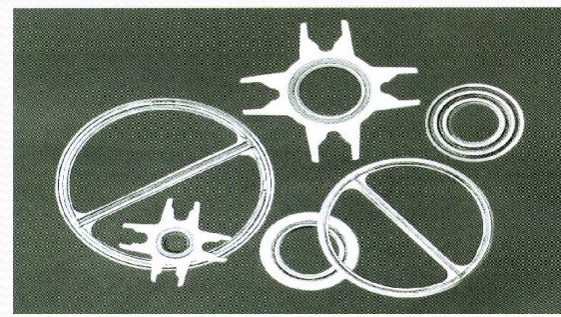
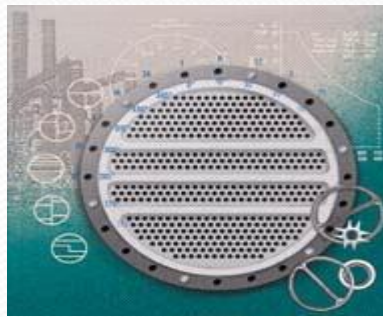
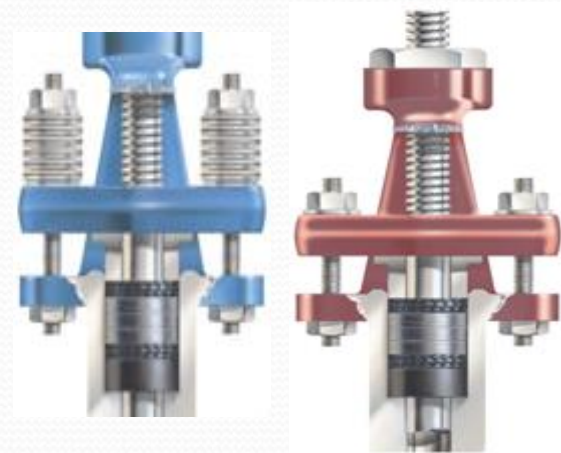



CHESTERTON[®]

Global Solutions, Local Service.

Gaxeta Injetável CMS 2000

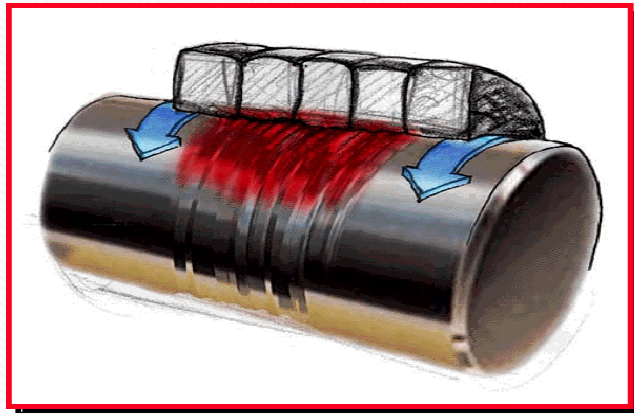

Desgaste do eixo com gaxeta comum

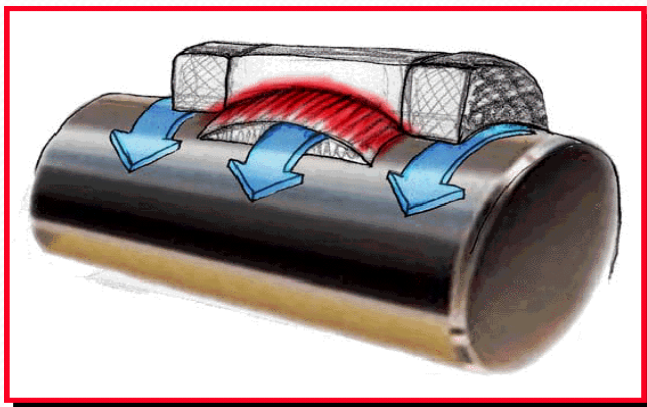

Desgaste do eixo com gaxeta Injetável



Injeção de gaxeta com a bomba em operação



CHESTERTON®

Global Solutions, Local Service.

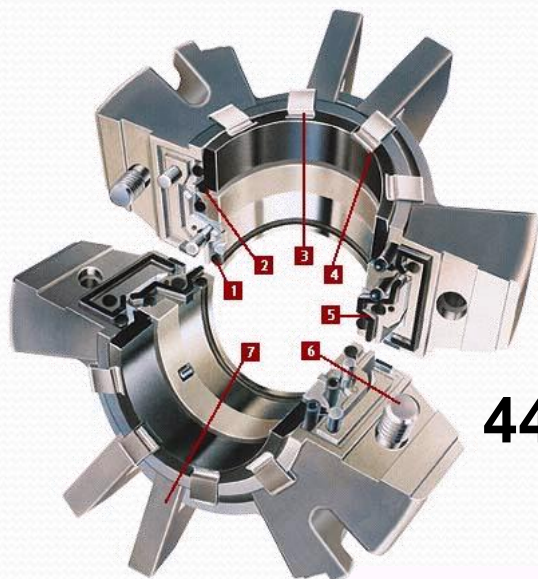

442

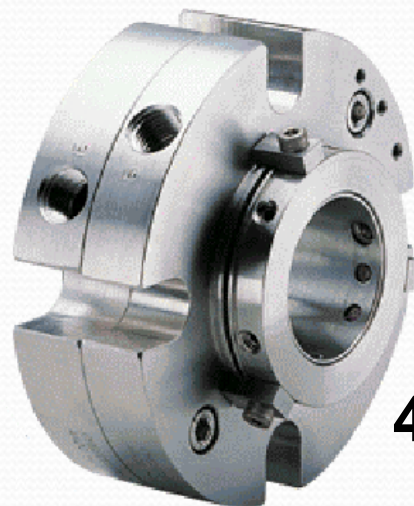

4400



491

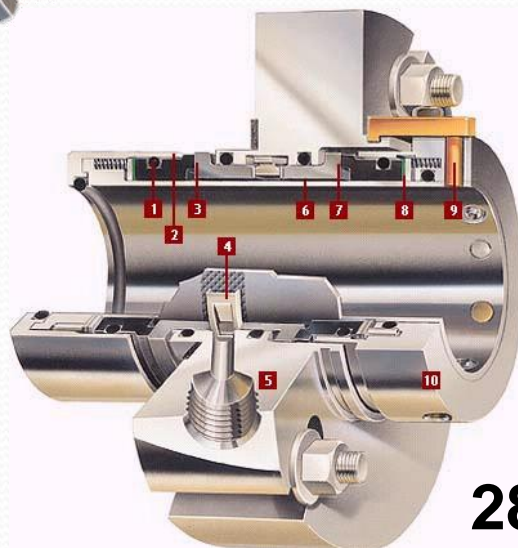

280



180

VETORBOMBAS →

Polímeros para: Corrosão/Erosão

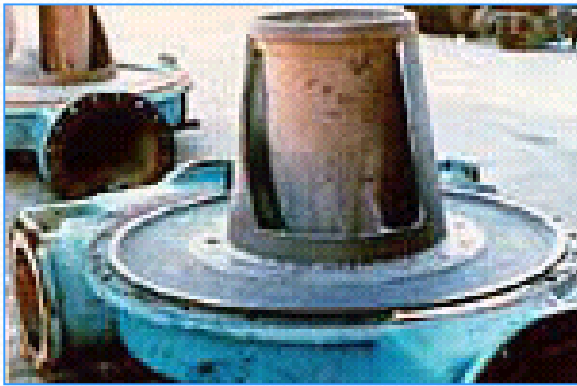

Ataque químico



Abrasão



Proteção concreto